

CYGNETT

RoamPWR 614Wh Expansion Battery Pack

CY5869CYP



Unlock helpful tips, safety info, and everything you need to get the most out of your new Power Station.

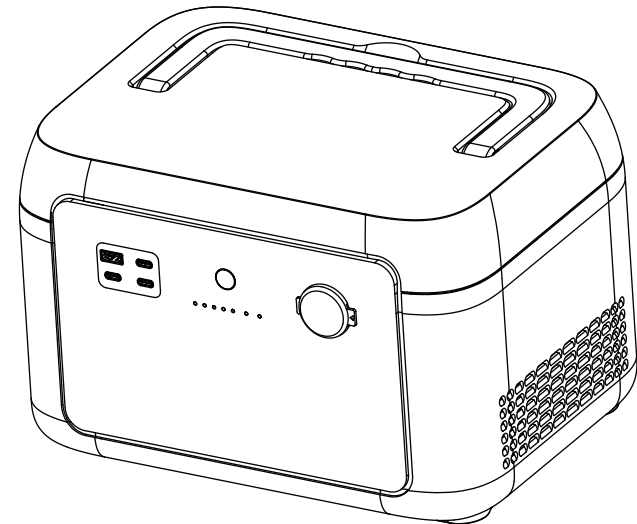

User Manual

Cygnett Pty Ltd 858 Lorimer St, Port Melbourne, Victoria 3207 Australia

Cygnett USA Inc 3838 W Carson St, Ste 220, Torrance, CA 90503

Cygnett UK Ltd 71-75 Shelton St, London, WC2H 9JQ

Cygnett NZ Ltd Level 9, 45 Queen Street, Auckland 1010

Cygnett EU Authorised Representative 24hour-AR, Van Nelleweg
1, 3044 BC Rotterdam, The Netherlands

Content

1.Parameters	1
2.Safety guidelines	2
2.1 Warning	2
2.2 Discard	2
3.Product display	3
4.Use	4
5.PV charging	4
6.Car charging	5
7.Parallel connection method	5
8.Indicator light	8
9.What' s in the box?	11
10. FAQs	11
11.Maintenance	12
12. Disclaimer	12

1. Parameter



General

Item No	CY5869CYPPS
Product Name	RoamPWR 614Wh Expansion Battery Pack
Net Weight	≈7.5kg
Dimension	301*227*193mm
Nominal energy	614Wh
Nominal capacity	12Ah
Nominal voltage	51.2V 
Operating humidity	10%-85%(Non-condensing)
Altitude	<2000m
Current	Charge: 12A Max., Discharge: 24A Max.

Output

Power-output	40-57.6V  , 24A Max.
USB-A1	5V  , 2.4A, 12W Max.
USB-C1	5/9/12/15V  , 3A, 20V  , 5A, 100W Max.
USB-C2/C3	5/9/12/15V  , 3A, 20V  , 3.25A, 65W Max.
Car charger	12.6V  , 10A Max.

Input

Power-input	40-57.6V  , 12A Max.
PV charge	13-45V  , 12A, 400W Max.
Adapter input	21V  , 5A, 105W Max.
Car charger	12/24V, 5A Max.

Battery

Cell Type	Lithium iron phosphate battery (LiFePO ₄)
Life Cycle	3000 cycles
Protection type	Over temperature protection, low temperature protection, over discharge protection, over charge protection, over load protection, short circuit protection , over current protection

* Test conditions: 95% DOD, 0.5C charge & 1.0C discharge at +25±3°C.

Operating Temperature

Discharge temperature range	-20°C~45°C
Charge temperature range	0°C~45°C
Storage ambient temperature	-20°C~45°C (20°C~30°C Preferred)

*Whether this product can be charged or discharged depends on the actual temperature of the battery pack.

2. Safety guidelines

2.1 Warning

1. Do not let a working expansion battery pack be close to the heat source, such as fire or heater.
2. Do not make expansion battery pack contact with any liquid. Do not immerse this product in water or get it wet. Do not use this product in the rain or in a wet environment.
3. Do not use this product in a strong electrostatic or strong magnetic field environment.
4. Do not disassemble in any way or pierce it with a sharp object.
5. Do not use wires or other metal objects to short-circuit the product.
6. Do not use parts or accessories that are not officially supplied. If replacement is required, please visit the official website for related information.
7. When using this product, please strictly follow the ambient temperature in this User Manual. If the temperature is too high, the battery may fire or even explode; if the temperature is too low, the product's performance will be severely degraded, or it may not be able to meet the requirements for normal use.
8. Please do not put other heavy objects on the expansion battery pack except the expansion battery pack; the stacking method of the expansion battery pack has been designed and tested by structural mechanics. For the stacking method of the expansion battery pack, please refer to the chapter 7 of this user manual.
9. Do not stop the fan by force or expose expansion battery pack in a non-ventilated or dusty environment when it is working.
10. Please avoid collision, drop, and violent vibration. If severe impact happens, shut down the power supply immediately. Please fix expansion battery pack firmly during transportation to avoid vibration and impact.
11. If expansion battery pack falls into water accidentally, place it in a safe and wide area, and keep yourself away from it until it's dry. Dried product shall not be used again. Dispose it properly according to chapter 2.2 in this user manual. If expansion battery pack is on fire, please use fire extinguishing equipment in the recommended order: water or water mist, sand, fire blanket, dry powder, dioxide carbon fire extinguisher.
12. If there is dirt on the connector of this product, wipe it off with a dry cloth.
13. Be careful to store the product so that it does not fall over and cause damage. If the product is tipped over and severely damaged, immediately turn it off, place the battery in an open area, away from combustible materials and people, and dispose of it in accordance with local laws and regulations.
14. Please store this product out of the reach of children and pets.
15. The product should be stored in a dry and ventilated place.
16. Warning: Operation of this equipment in a residential environment could cause radio interference.

2.2 Discard

1. When conditions permit, please be sure to completely discharge the battery of this product before placing the product in the designated battery recycling bin. This product contains batteries, batteries are hazardous chemicals, it is strictly forbidden to waste in ordinary garbage bins. For details, please follow local laws and regulations on battery recycling and disposal.
2. If the battery cannot be completely discharged due to the failure of the product itself, please do not dispose of the battery directly in the battery recycling bin, but contact a professional battery recycling company for further disposal.
3. The battery will not start after over-discharging, please dispose of it as discarded.

3. Product display



1. This product can be used alone, with USB-A and USB-C and car charger interface to power electronic devices.
2. It can be used with our 1kW power station to increase the battery life of the power station.
3. When the battery packs are used in parallel, any power button can wake up the parallel battery packs.

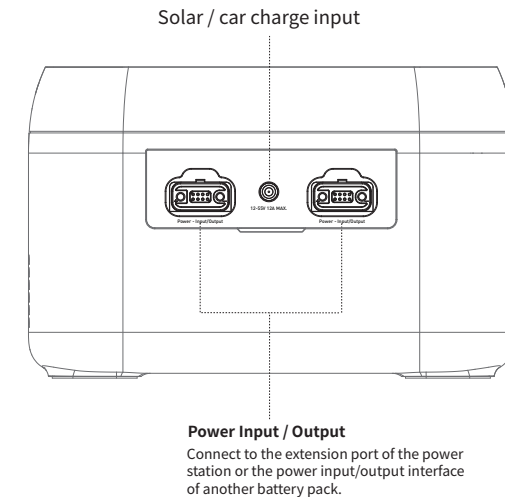
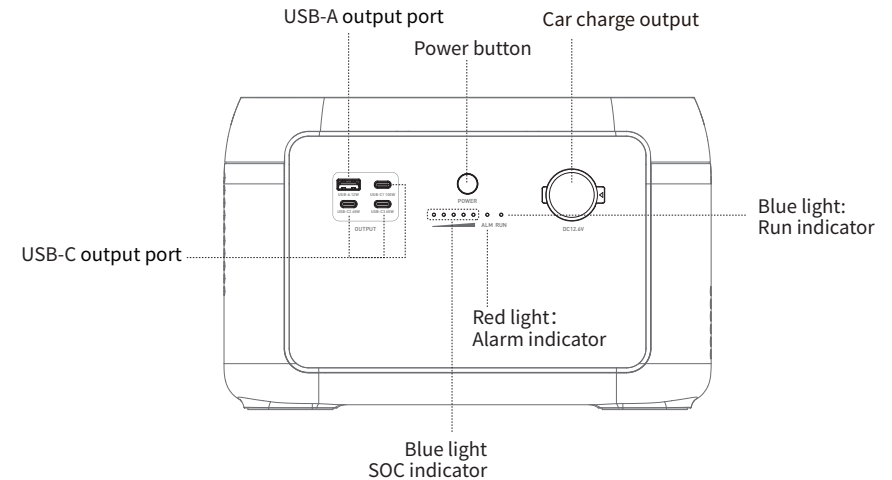

4. Use

Power on: Short press the power button for 1 second to power on, the indicator light will light up, and the SOC power and operating status will be displayed.

Power off: Press and hold the power button for 3 seconds to shut down, the indicator light will turn off.

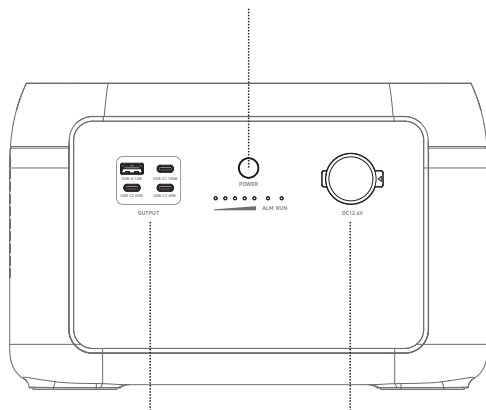

USB output

USB output is enabled by default after the main power switch is turned on.

12V DC output

The 12V DC output is enabled by default after the main power switch is turned on.

5. PV charging

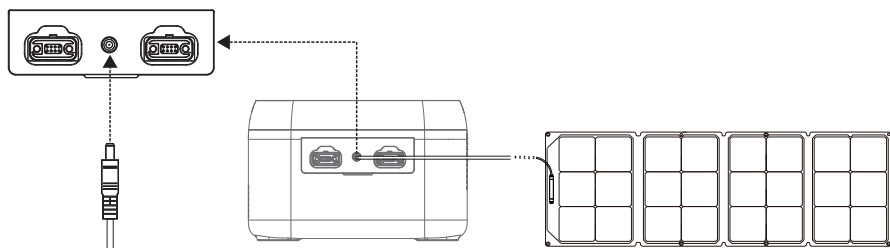

Charge the power station by solar panel

*Solar charging cable (DC7909)

- Please follow the user manual to connect the solar panels.
- Before connecting the solar panel, check whether its output voltage is within power station specifications to avoid damage to power station.

*The interface of this product is DC7909. If you need an adapter cable from MC4 to DC7909, please purchase it yourself.

6. Car charging

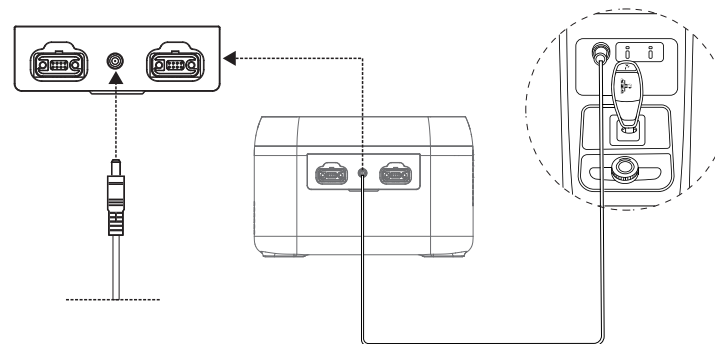

*Car charger cable (DC7909)

Power station can be charged by a car charging port. It should be charged after the car starts, so as to avoid the car battery loss and failure to start. At the same time, ensure good connection between the car charging port and cigarette lighter. We take no responsibilities for any loss caused by improper operation.

7. Parallel connection method

Power station supports connection with 6 expansion battery packs at the same time for larger capacity. Please refer to the user manual of battery pack for details.

Please note the following when using

- Before connecting the expansion battery pack, please ensure that the power station and the expansion battery pack are both in the offstate.
- After connecting the expansion battery pack, make sure that the number of parallel expansion battery pack icon appears on the LCD of the power station. before starting to use it.
- Please do not connect or remove the power station. Directly, during the charging and discharging process, if you need to connect or remove the expansion battery pack in process, please turn off the power first and then operate.
- Do not touch the metal terminal at the connection port of expansion battery pack with your hands or other objects, if the metal terminal is attached to other objects, please gently wipe it clean with a dry cloth.

Parallel mode of 1 power station and 1 expansion battery pack:

- 1 Turn off the power station and expansion battery pack.
- 2 The expansion cable plugs into the expansion port of the power station and the Power Input/Output of the expansion battery pack.
- 3 After parallelization, press power button  of power station to enable the power station and battery pack to show current capacity. The power station shows the paralleled quantity, and capacity is expanded.
- 4 After parallelization, connect ports of the power station for charging or discharging (refer to the Power Station User Manual 3.3, 3.4, 3.5 and 3.6).

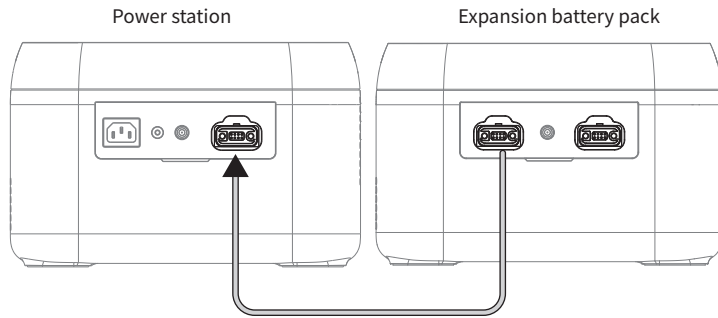

Notes

Both ports of the expansion battery pack can be connected to the expansion port of the power station.

Both ports of the expansion cable can be connected to the ports of the expansion battery pack and the expansion port of the power station.

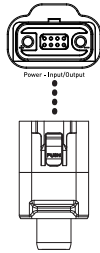

Parallel mode of 1 power station and multiple expansion battery packs:

- 1 Turn off the power station and expansion battery packs.
- 2 The expansion cable plugs into the expansion port of the power station and the Power Input/Output of expansion battery pack 1, the Power Input/Output of expansion battery pack 1 connects to the Power Input/Output of expansion battery pack 2, the Power Input/Output of expansion battery pack 2 connects to the expansion battery pack 3. 6 battery packs can be parallelized at most.
- 3 After parallelization, press power button  of the power station to enable the power station and battery packs to show current capacity. The power station shows the paralleled quantity, and capacity is expanded.
- 4 After parallelization, connect ports of the power station for charging or discharging (refer to the Power Station User Manual 3.3, 3.4, 3.5 and 3.6).

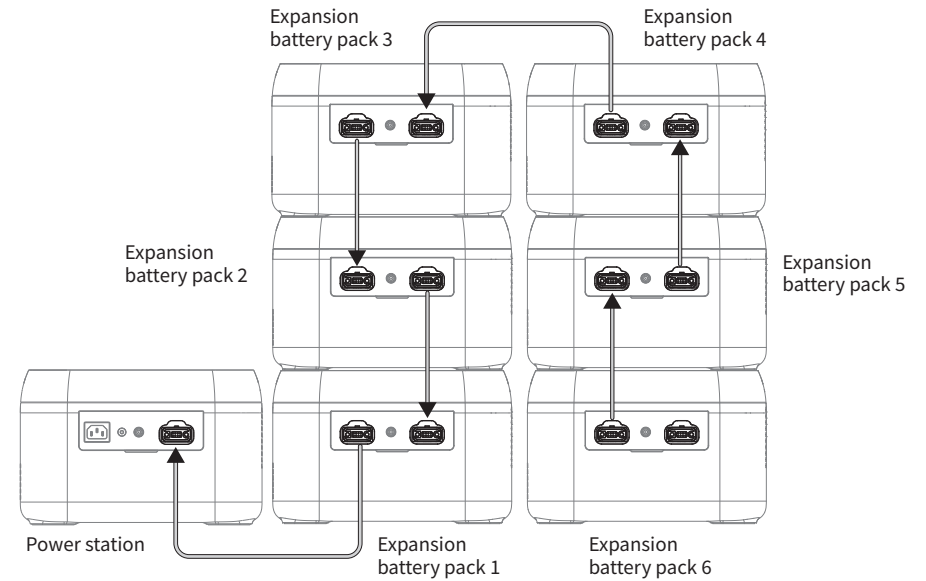

Notes

Both ports of the expansion battery pack can be connected to the expansion port of the power station.

Both ports of the expansion cable can be connected to the ports of the expansion battery pack and the expansion port of the power station.

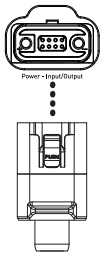

8. Indicator light

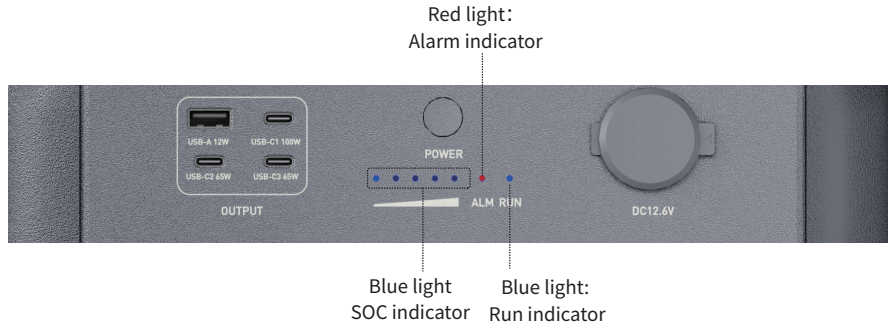

Indicator status

Indicator	Status
Blue light: SOC indicator	SOC indicator
Red light: Alarm indicator	Alert, faulty
Blue light: Run indicator	Standby, working

Normal state

SOC indicator	Description
	$0\% \leq \text{SOC} \leq 20\%$
	$20\% < \text{SOC} \leq 40\%$
	$40\% < \text{SOC} \leq 60\%$
	$60\% < \text{SOC} \leq 80\%$
	$80\% < \text{SOC} \leq 100\%$

Alerting

Button Indicator	SOC indicator	Alerting	Solution
Red light blinks		Battery over voltage	Restart the battery. If it's still not fixed, contact customer service.
		Battery under voltage	Charge the battery, waiting for the voltage to recover.
		Unit under voltage	
		VTOP under voltage	
		VTOP over voltage	Restart the battery. If it's still not fixed, contact customer service.
		Battery over temperature	Turn off and wait for 2 hours. If it's still not fixed, contact customer service.
		Battery low temperature	Turn off, wait the temperature to recover, restart the battery. If it's still not fixed, contact customer service.
		Overcurrent when charging	Restart the battery. If it's still not fixed, contact customer service.
		Overcurrent when discharging 1	
		Overcurrent when discharging 2	
		Short when discharging	Turn off, remove and check equipment, restart the battery. If it's still not fixed, contact customer service.
		Short when charging	
		PCB over temperature	Turn off and wait for 2 hours. If it's still not fixed, contact customer service.
		Pre-charge resistor over temperature	
		Battery under voltage	Charge the battery, waiting for the voltage to recover.
		UIIP parallel signal fault	Turn off, check the communication cable, restart the battery. If it's still not fixed, contact customer service.
	I_WORK parallel signal fault		
	Parallelization over time		
	Parallelization readiness failure		

Remark

- It is recommended to restart by the switch button.
- When parallelization is applied, after the battery under voltage protection and powered off, only need to press the button switch on any battery to forcibly activate it.

Faulty

Button Indicator	SOC indicator	Alerting	Solution
Red light always on		Battery voltage sampling wire broken	Restart the battery. If it's still not fixed, contact customer service.
		MOS failure	
		AFE communication failure	
		EEPROM failure	
		Voltage sensor failure	
		Current sensor drift failure	Contact customer service.
		Main circuit fault	
		Pre-charge over time	Restart the battery. If it's still not fixed, contact customer service.
		Current sensor failure	
		Dead battery	
		Inverter communication failure	Turn off, check the communication cable. If it's still not fixed, contact customer service.
		CAN bus failure	
		RS485 bus failure	
		Parallel address recognition failure	
		Short circuit protection fuse circuit fault	Contact customer service.

9. What's in the box?

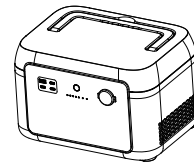

Expansion battery pack



Expansion cable

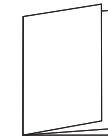

User manual

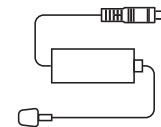

Adapter

10. FAQs

1. What kind of battery is used?

Lithium iron phosphate battery (LiFePO₄).

2. How to know the supply time?

The LED screen of the portable outdoor power station displays the charge level of the expansion pack.

3. How to know it is charging?

When in charge, the power indicators will flash to showing the charging state.

4. How to clean the product?

Clean the unit with a dry, soft and clean cloth or tissue.

5. How to store the unit?

Turn it off, and keep it in a dry and ventilated place. Do not expose it close to water. For long-term storage, charge and discharge every 3 months. (i.e. discharge to 0% then charge to 100%, then discharge to 60% for long-term storage.)

6. Can it be taken on board?

No.

11. Maintenance

- Keep it away from water, heater and metal parts.
- It is recommended to use or store expansion battery pack under 20~30°C ambient temperature.
- For long-term storage, charge and discharge every 3 months. (i.e. discharge to 0% then charge to 100%, then discharge to 60% for long-term storage.); products that have not been charged and discharged for more than 6 months are not warranted.
- For safety, do not store expansion battery pack with temperature above 45°C or below -10°C.
- If the capacity is seriously insufficient and idle time is too long, the product will enter deep sleep mode, and the product can only be used after being charged.

12. Disclaimer

Before using the power station expansion battery pack, please read this user manual to ensure understanding and proper use. After reading the user manual, please keep it well for future reference. Improper operation may cause serious injury to yourself or others, or result in product damage and property loss. Once using expansion battery pack, you are deemed to have understood and accepted all terms and contents herein. Users promise to be responsible for their actions and all consequences arising therefrom. We shall not be liable for any loss arising from user's not following this user manual.

In compliance with laws and regulations, the company reserves the right of final interpretation of this document and all related documents of this product. Subject to update, revision or termination without prior notice, please visit the the official website for the latest product information.